

3J DRIVELINE GROUP 1 /ATLAS / GIV & HD HALF SHAFT SET

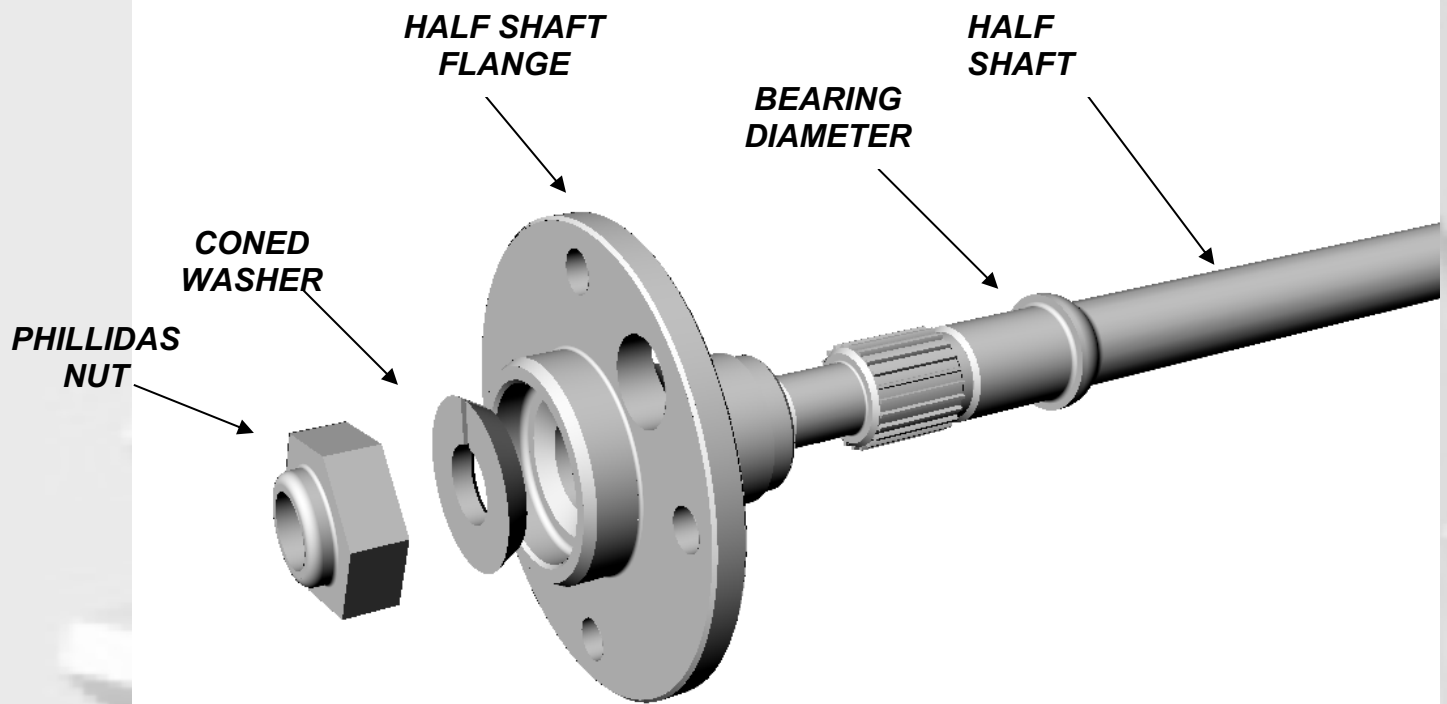

3J's GROUP 1 / ATLAS/GIV & NEW HD (HEAVY DUTY) HALF SHAFT SET IS DESIGNED TO GIVE YOU A RELIABLE AND SIMPLE TO FIT TWO PIECE SHAFT SYSTEM TO REPLACE THE WEAKER STANDARD FORD ITEMS.

MANUFACTURED FROM HIGHER GRADES OF MATERIAL, OUR SHAFT GIVES YOU THE CONFIDENCE TO PUSH INTO EVERY CORNER. COMPLEMENTED WITH A CONED WASHER (CONED WASHER NOT APPLICABLE IN ATLAS/GIV SHAFT SETS) AND SELF LOCKING PHILLIDAS NUT, ELIMINATING THE OLD PROBLEM OF THE NUT LOOSENING.

THERE ARE A RANGE OF LENGTHS AND DIFFERENT SPLINES TO SUIT THE ATLAS AND ENGLISH. COMPATIBLE WITH WHEEL STUDS, 7/16" OR 12MM IN TWO LENGTHS.

PLEASE ENSURE YOU HAVE THE CORRECT LENGTH SHAFT BEFORE FITMENT AS DAMAGE CAN BE CAUSED IF NOT CORRECT

TECHNICAL INFORMATION

Phillidas Nut Torque value (Please use thread Fastener).....120lb/ft

Wheel Stud Diameter.....7/16"/12mm

Nut Thread.....7/8 14 UNF